

## ASSEMBLY INSTRUCTIONS

**MODEL#:**

**BBHDDM10/BBHDDM50 DRY LINER**



CUSTOMER SERVICE: 1-800-527-7510

PO#:

## PARTS LIST

PARTS DESCRIPTIONS	Q'TY
1. Bucket & frame assembly	1pc
2. Handlebar frame	1pc
3. Triangular support plate	2pcs
3a. M6 bolt	4pcs
7. Washer 12mmdia for M6 bolt	8pcs
9. Lock nut for M6 bolt	4pcs
4. Lever & rod assembly	1pc
5. Hex bolt M8x35mm	4pcs
6. Washer 16mmdia for M8 bolt	8pcs
7. Washer 12mmdia for M6 bolt	2pcs
8. Lock nut for M8 bolt	4pcs
9. Lock nut for M6 bolt	2pcs
10. Screw M4x10mm	1pc
11. Forelock	1pc
12. Notched plate	1pc
13. Spring	1pc

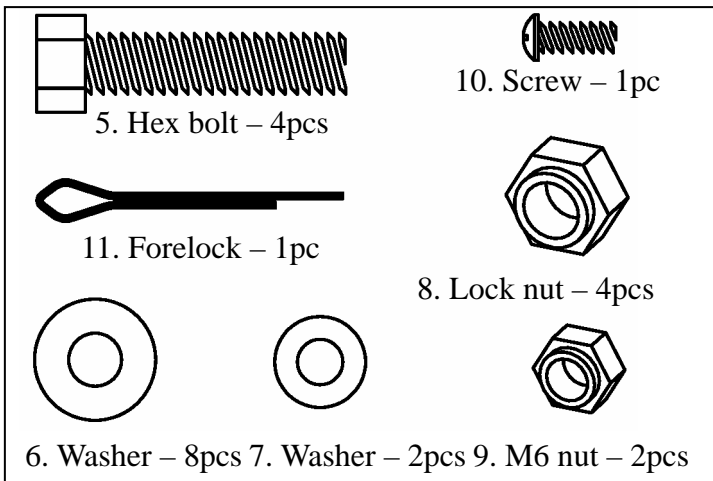

### Step 1

Remove the attached bolts and nuts on the triangular support plate (3). Install the Triangular support to the Bucket (1) using the removed parts. Hand tight it securely. Do not use wrench at this time.

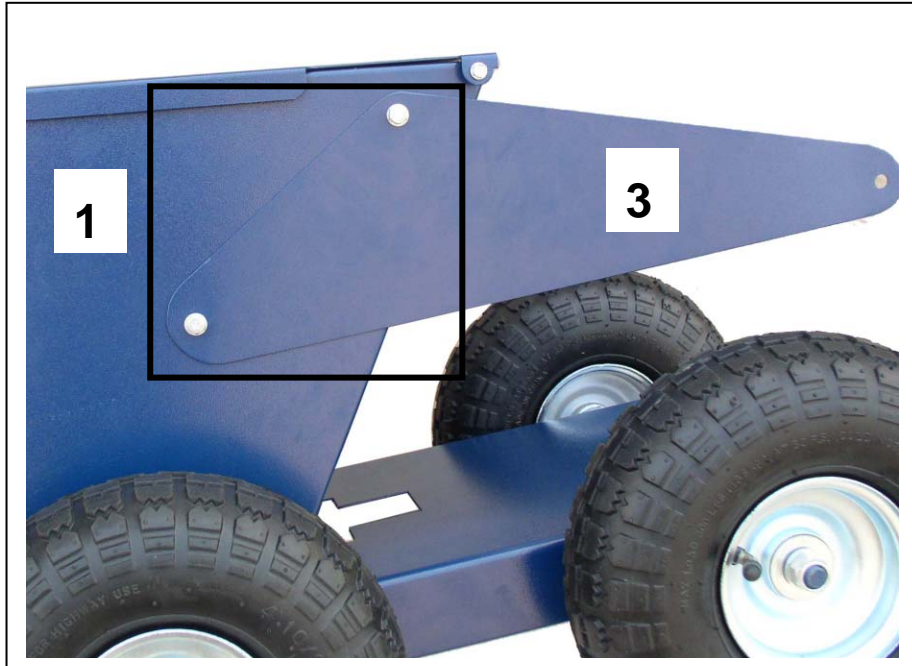

### Step 2

Attach the Handlebar frame (2) to the Triangular support plate (3) using 2 Hex bolts (5), 4 washers (6) and 2 lock nuts (8). See Figure A.

Attach the handlebar frame (2) to the Bucket & frame assembly (1) using 2 Hex bolts (5), 4 washers (6) and 2 lock nuts (8). See Figure B.

Tighten all the bolts and nuts used in Step 1 & Step 2.

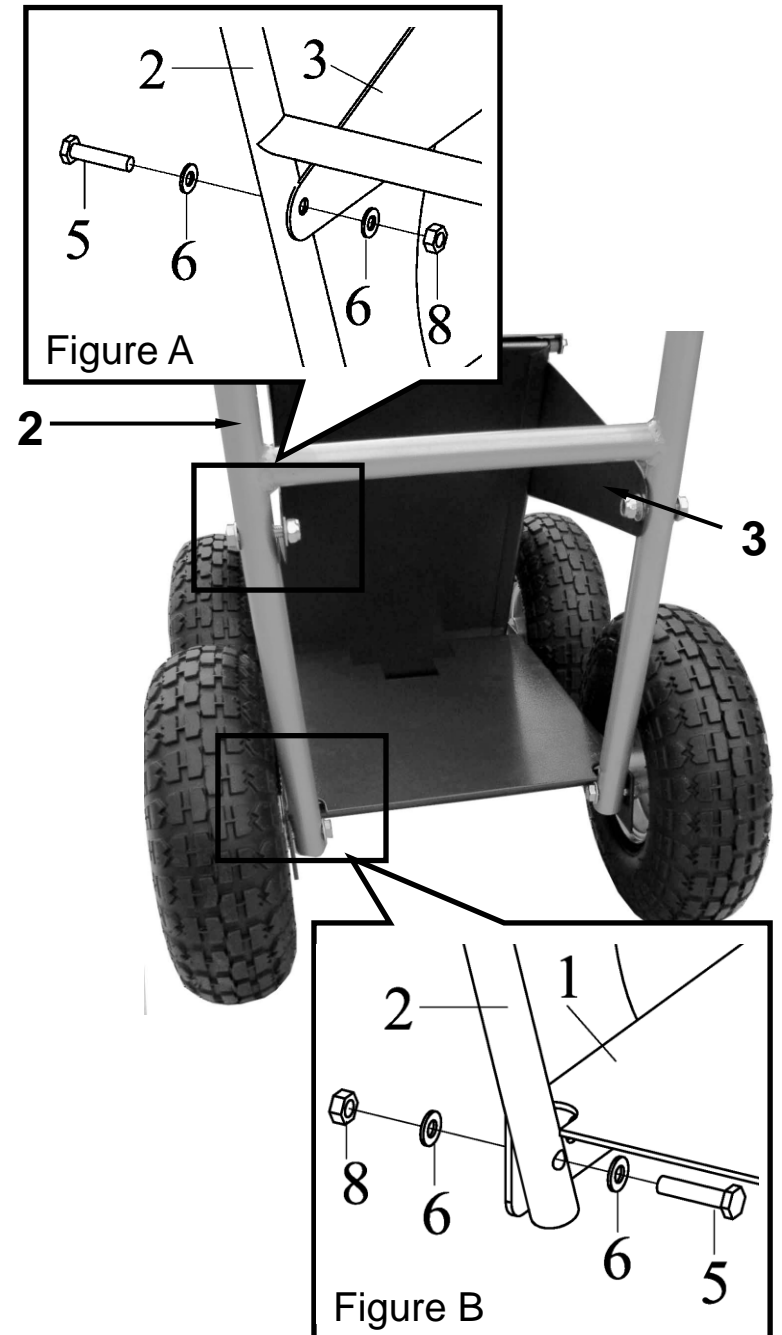

### Step 3

Attach the Notched plate (12) to the threaded rod welded on the Handlebar with one Lock nut (9), secure it in place with one Screw (10).

Connect the Lever assembly (4) to the threaded rod. Secure it in place with 2 washers (7), one Spring (13) and one Lock nut (9). Do not over-tighten it.

Attach the other end of the Lever rod (4) to the adjusting lever. Lock it in place with one forelock (11).

